

INSTALLATION INSTRUCTIONS

Read the Following Information Carefully Before Use

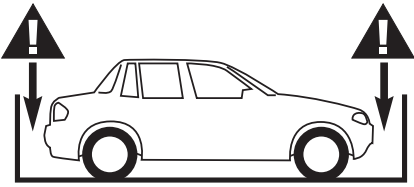

WARNING



- ⚠ This system is designed to allow your vehicle to ride freely on its own suspension. To avoid vehicle damage, allow a minimum of 10" clearance in-front, behind, and from the sides vehicle.
- ⚠ Transported vehicles should be in park or in gear with the parking brake set.
- ⚠ Vehicles and straps may shift during transport. Check and adjust your tension and vehicle position every 50 miles.
- ⚠ Always secure any vehicle for transport by all four tires.

Ratchet Buckle Operating Instructions

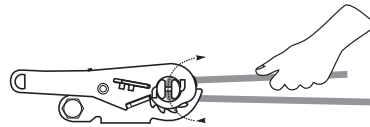

Feed webbing through mandrel from bottom

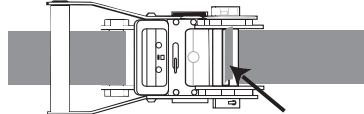

Feed through mandrel slot

- 1 To install the strap, feed the plain end of the webbing through the slot in the mandrel of the ratchet buckle, and remove all slack by hand. Do not proceed to step 2 until all slack is removed.

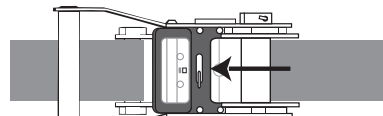

To release

- 3 To remove tension from the strap, the ratchet buckle must be opened completely. Squeeze and hold the release handle while fully opening the buckle. See figure A

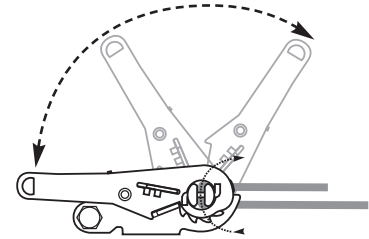

- 2 To tension the strap operate the ratchet buckle as shown above. A minimum of 1 full wrap and no more than 2 full wraps are required. Hand tension only. Do not over-tension.

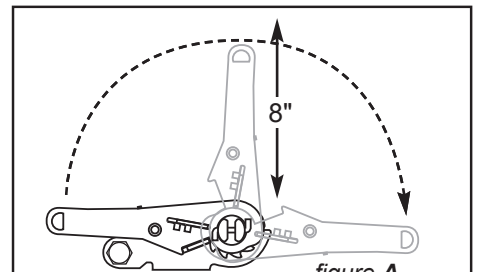

figure A

Fully released position

IMPORTANT Before tensioning the strap, make sure there is at least 8" of clearance above the buckle, allowing it to open completely for tension removal.

Tire Harness Installation Instructions

- 1 Place basket securely around top of tire with tension straps facing out and down.

Make certain the back portion of the strap only contacts the tire and rim and is clear of any mechanical components such as brake lines.

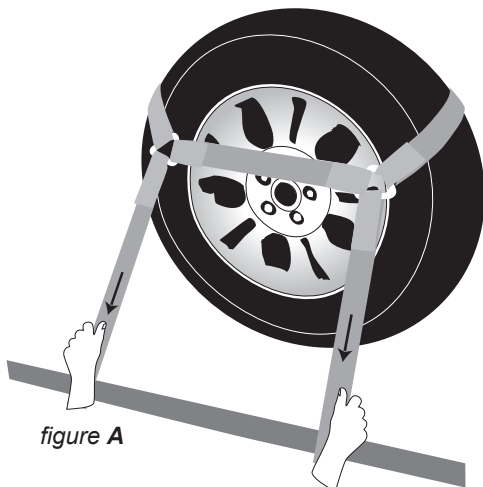

figure A

- 2 Feed tension straps through ratchet buckles. See figure C

IMPORTANT
Pull basket down on tire to remove all slack until strap lays flat and snug around tire. See figure A

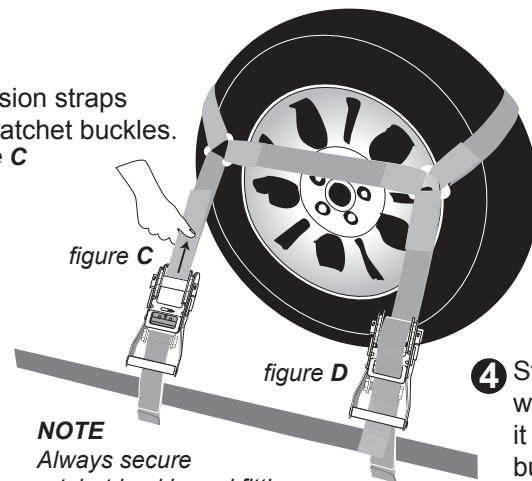

figure C

figure D

- 4 Store surplus webbing by tucking it through the buckle as shown. See figure D

NOTE
Always secure ratchet buckle and fittings to approved tie down point on your trailer. Refer to your trailer manufacturer's owners manual.

- 3 Plant both feet firmly on the ground. Tighten assembly per instruction 2 as described above in the Ratchet Buckle Operating Instructions. Apply even tension to both straps. **TIP** Alternate tension on each strap until both sides are fully secure.

- ⚠ Hand tighten only. Do not over tension.
- ⚠ Always secure any vehicle for transport by all four tires.